



SOLUTIONS for

Pneumatic Conveying

VACUUM

PRESSURE



Palamatic

PROCESS >>> machines • engineering

Powder Handling Solutions

CONTENT



Means that the equipment is available for testing at PALAMATIC PROCESS



Means that the equipment can be installed in ATEX zone



Means that design and options can be customised

PALAMATIC PROCESS reserves the right to make changes in the design of the facilities listed in this commercial documentation

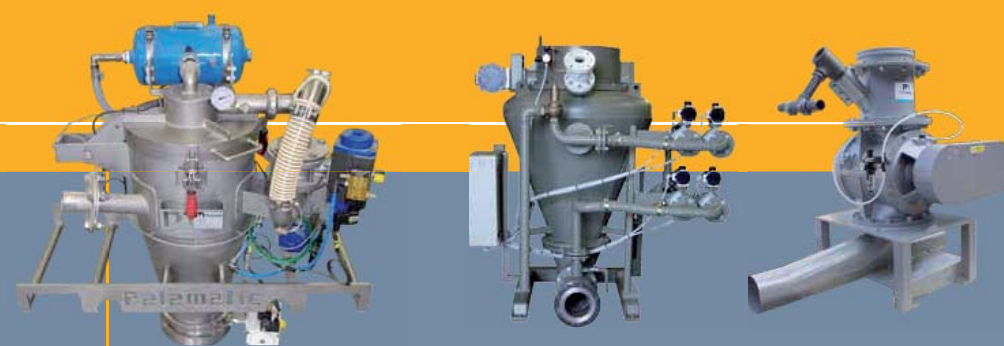

● PNEUMATIC CONVEYING: TECHNOLOGIC CHOICE 02

● DENSE PHASE VACUUM CONVEYING SYSTEM 05

Pumps for powders STANDARD RANGE

- VFlow® 01 08
- VFlow® 02 09
- VFlow® 03 10
- VFlow® 04 11
- VFlow® 05 12

Custom made VFlow® 13

Clean In Place 14

Examples of installations 15

Detached filter 16

ATEX 19

Included weighing 20

Options 23

Automation 26

Test Plant 28

● DENSE PHASE PRESSURE CONVEYING SYSTEM 29

Inflatek® valve 34

Examples of installations 35

● DILUTE PHASE CONVEYING - BLOWER 37

Cyclofilters range 42

Design office 44

Examples of installations 46

● ACCESSORIES 48

Pipes and switches 48

Peripheral accessories 49

● ATEX 50

ATEX installation conception guide 50

ATEX guide 52

A TECHNOLOGY ADAPTED TO EACH PROCESS

Pneumatic conveying is as an alternative to the mechanical conveying of the materials. The conveying of the bulk materials operates by known methods of **pressure or suction**.

Pressure pneumatic transfer is particularly suitable for the transport of materials having high flow rates (up to 200 t./h.) and for medium to long distances (50 to 150 m.). Our range of dense phase pneumatic conveying systems has been designed to be a simple and effective method of transferring material from a single collection point to either a single or multiple reception points.

Vacuum pneumatic transfer is used to transport over short and medium distances (from 2 to 80 m.) powders or granules that are sensitive to heat, sticky or hygroscopic with a tendency to clog.

Pneumatic conveying systems are normally divided into two types depending on if the solids-air ratio is high (**dense phase**) or low (**dilute phase**).

Dilute phase vacuum conveying systems are particularly suitable for systems which convey materials at low to moderate capacities over medium distances, from multiple points to a single destination. These systems are versatile and adaptable for different materials and the low operating pressures allow lower cost pipelines and fittings.

Dense phase vacuum conveying systems are particularly suitable for systems which convey materials at high capacities over short to medium distances, from multiple sources to a single or multiple destinations. The low convey velocities and vacuum method make it suitable for food, dairy and pharmaceutical applications with friable or fragile agglomerated powders.

STANDARD INSTALLATIONS WITH DENSE PHASE VACUUM CONVEYING SYSTEM

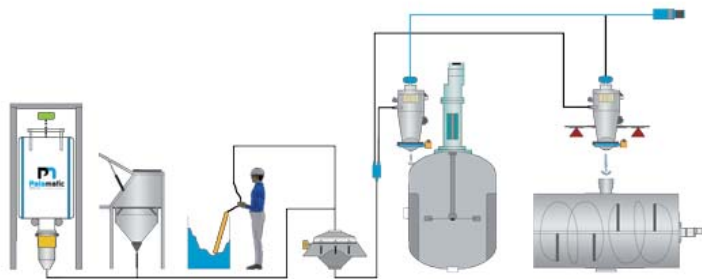

[+] Advantages

- ▶ Vacuum of multiple reception points
- ▶ ATEX Security
- ▶ Integrated weighing equipment (loss-in-weight, weight gain)

STANDARD INSTALLATIONS WITH DILUTE PHASE PRESSURE CONVEYING SYSTEM - BLOWER

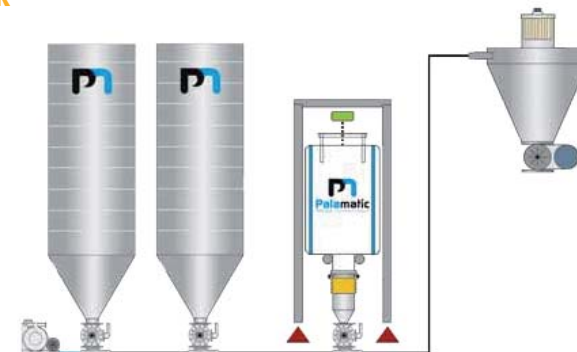

[+] Advantages

- ▶ Reduced cost
- ▶ Multiple arrival points
- ▶ Easy to install

STANDARD INSTALLATIONS WITH DENSE PHASE PRESSURE CONVEYING SYSTEM

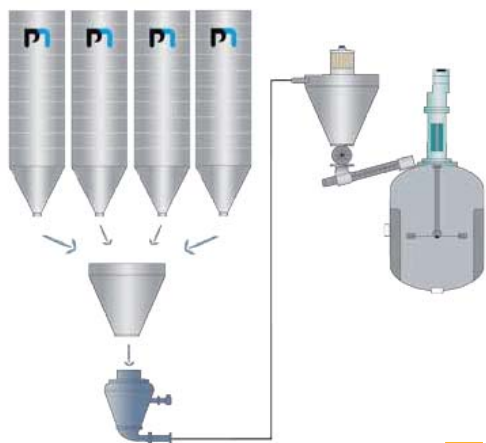

[+] Advantages

- ▶ High convey rates
- ▶ A reduced abrasiveness

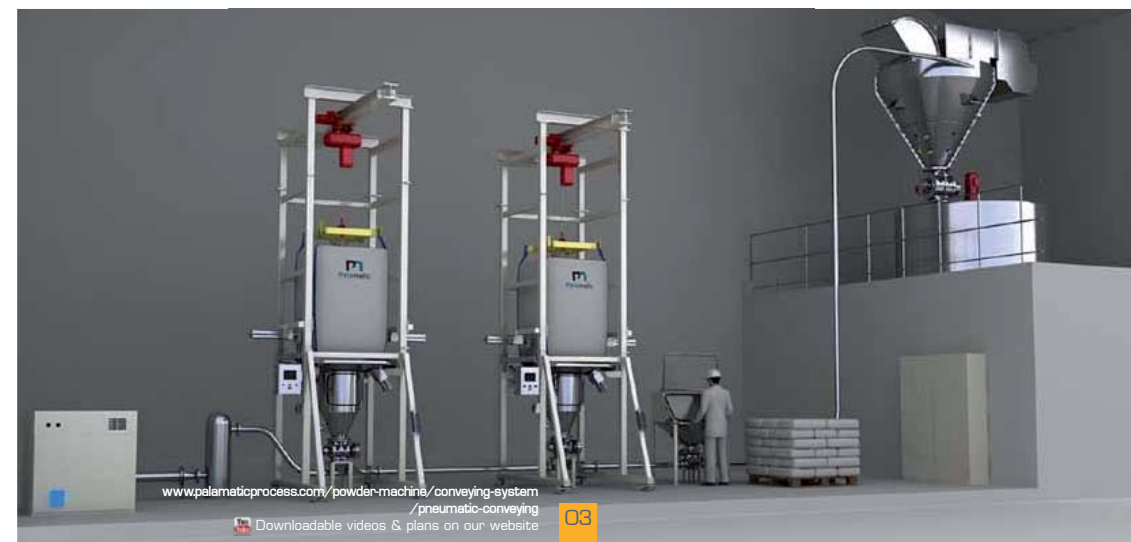

Technological Choice



Dense Phase Vacuum Pneumatic Conveying

Equipment
TEST CENTER
Available

CAPTION : Not applicable ✓ Applicable

Characteristics of the solutions

	Vacuum dense phase	Pressure dense phase	Pressure dilute phase
Maximum Rates*	6 to 8 t./h.	100 t./h.	40 t./h.
Maximum conveying distance	70 m.	700 m.	200 m.
Convey velocity	Low	Low	High
Convey rates	Negative	High	Low
Piping abrasion	Low	Low	High
Risk of damage of the mixing quality	Low	Low	High
Amortization/Investment	Medium	High	Medium
Energetic cost	Low	Medium	High
Operating cost	Low	Low	Low
Hygienic application	✓		
Multiple arrival points	✓	✓	✓
Multiple start points	✓		✓
ATEX application	✓	✓	✓
Integration of weighing device at the start	✓	✓	✓
Integration of weighing device on arrival	✓		✓
C.I.P. (Clean In Place)	✓		✓

*Flow rates are indicative and may vary depending on material type.

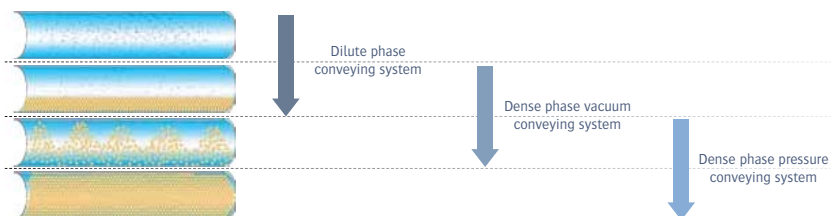

VFlow® Range



OPERATING PRINCIPLE

Dense phase vacuum conveying systems use high capacity vacuum pumps to convey materials from a feeding hopper or a silo to a receiving vessel (vacuum hopper) where the air and product are separated by a filter. When this vessel is full, the vacuum is isolated and the conveyed product is discharged. Particularly adapted to difficult products, this cyclone can be easily set up in your environment with unlimited extension possibilities. Suction is performed from several feeding points and/or loading several points in your process. Coupled with weighing systems, it allows controlled introduction by weight of raw materials (bulk powders, granules...).

ADVANTAGES

- Flexibility of the system through time
- Purge of the line
- Clean In Place
- Hygiene
- Loading of pressurized reactor
- Easy operation
- All products (bulk, powder, granules...)
- All rates
- No degradation of the conveyed material

IDEAL SOLUTION

FOR FEEDING:

- Powder moisteners
- Mixers
- Tanks
- Reactors
- Pressurized reactors
- Dispensers loaded with solvents
- Filling machines...



SYSTEM OVERVIEW

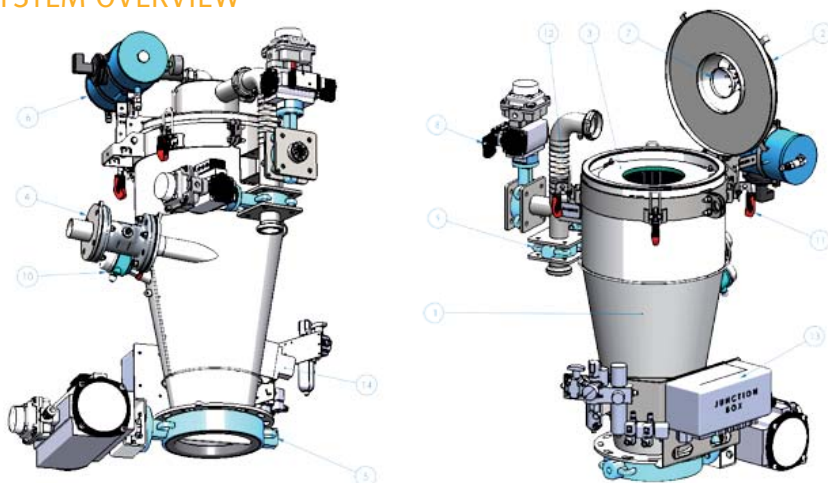

Part n°	Denomination	Manufacturing	Qty
1	Body	Stainless steel 304L	1
2	Cover	Stainless steel 304L	1
3	Removable filtering cartridge	Height 350 mm - Ø 325mm	1
4	DN65 Inlet product valve	Pinch valve	1
5	DN250 Outlet product valve	Butterfly valve - Cast iron body - Stainless steel disc	1
6	Unclogging tank	Painted steel cylinder - Aluminium solenoid valve	1
7	Unclogging nozzle	ABS	1
8	DN65 Valve for venting	Butterfly valve - Cast iron body - Stainless steel disc	1
9	DN65 Vacuum valve	Butterfly valve - Cast iron body - Stainless steel disc	1
10	High level probe	Capacitive technology	1
11	Spring clips for cover closing	Zinc plated steel - Bi-material plastic handle	4
12	Vacuum hose	Food quality polyurethane tube	1
13	Pneumatic equipment plate	Stainless steel 304L	1
14	Pneumatic vibrator	Aluminium	1

Note: materials and accessories may differ depending on your configuration

CYCLONES RANGE



Models	Overall height in mm.	Convey rate in m³/h.*	Ø Piping	Material outlet Ø	Compressed air consumption in m³/h.	Tare weight (kg)
VFlow® 01	880	0 to 1	SMS 38/51	DN 200	0.21 to 0.85	95
VFlow® 02	1,133	1 to 2.5	SMS 51/63	DN 200	0.46 to 1.06	115
VFlow® 03	1,311	2.5 to 4	SMS 63/76	DN 250	0.80 to 1.23	145
VFlow® 04	1,477	4 to 6	SMS 76/88.9	DN 300	0.63 to 0.92	170
VFlow® 05	1,644	5 to 8	ISO 88.9/104	DN 300	0.57 to 0.92	185

*Convey rates depend on the density of the conveyed material.

RATES / DISTANCES RATIOS

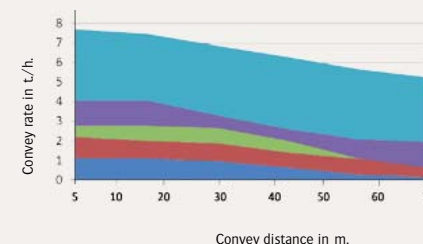

Granules, metallic powders or sticky materials, the VFlow® range ensures the conveying of more than 95% of existing powdered materials!

VFlow® 01



VFlow® 02



VFlow®

01

Dense phase vacuum conveying:
powder pump



Model: VFlow® 01
Rate: 0 to 1 m³/h.
Overall height: 879 mm.
Volume of the cyclone: 15 liters
Manufacturing quality: Ra < 1.2 to 0.8
Cyclone body manufacturing: 304(L) stainless steel, 316(L) stainless steel
Size of the particules transferred: from mm. to µm
Operating temperature: -10°/+ 40°
Vacuum pump technology: without lubrication, with dry paddles or nozzles
Tare weight: 95 kg
Maximum vacuum transfer: 800 Nm³/h.
Air consumption*: 0.21 to 0.85 m³/h.
 *Flow rate at atmospheric pressure, maximum and minimum rates
Operating pressure: 6 bars
Filter manufacturing: polyester, PTFE coated, stainless steel deployed inside
Filtering area: 2.6 m²
Unclogging tank volume: 6.5 liters
Level probe characteristics: capacitive (on request according to product)
Unloading valve technology: butterfly Ø DN200
Valve body: cast iron or 316L stainless steel
Valve disc: 304(L) stainless steel, 316(L) stainless steel
Product valve technology: pinch
Vacuum valve technology: butterfly with pneumatic actuator
Air suction pipe Ø (mm): DN40
Product suction pipe Ø (mm): 38 - 51
Piping type: rigid and flexible (reinforced piping with electrical spiral for metallic continuity)
Connections: SMS, clamp, flange
Power required: 2.2 to 3.3 kW
Inlet: 2
Outlet: 5
ATEX compatibility: 20, 21, 22 and 1, 2
Pump flow rate m³/h.: 140

02

Dense phase vacuum conveying:
powder pump



Model: VFlow® 02
Rate: 1 to 2.5 m³/h.
Overall height: 1.145 mm.
Volume of the cyclone: 25 liters
Manufacturing quality: Ra < 1.2 to 0.8
Cyclone body manufacturing: 304(L) stainless steel, 316(L) stainless steel
Size of the particules transferred: from mm. to µm
Operating temperature: -10°/+ 40°
Vacuum pump technology: without lubrication, with dry paddles or nozzles
Tare weight: 115 kg
Maximum vacuum transfer: 800 Nm³/h.
Air consumption*: 0.46 to 1.06 m³/h.
 *Flow rate at atmospheric pressure, maximum and minimum rates
Operating pressure: 6 bars
Filter manufacturing: polyester, PTFE coated, stainless steel deployed inside
Filtering area: 4.4 m²
Unclogging tank volume: 6.5 liters
Level probe characteristics: capacitive (on request according to product)
Unloading valve technology: butterfly Ø DN200
Valve body: cast iron or 316L stainless steel
Valve disc: 304(L) stainless steel, 316(L) stainless steel
Product valve technology: pinch
Vacuum valve technology: butterfly with pneumatic actuator
Air suction pipe Ø (mm): DN50
Product suction pipe Ø (mm): 51 - 63
Piping type: rigid and flexible (reinforced piping with electrical spiral for metallic continuity)
Connections: SMS, clamp, flange
Power required: 4 kW
Inlet: 2
Outlet: 5
ATEX compatibility: 20, 21, 22 and 1, 2
Pump flow rate m³/h.: 200 - 250

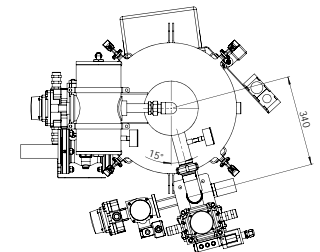
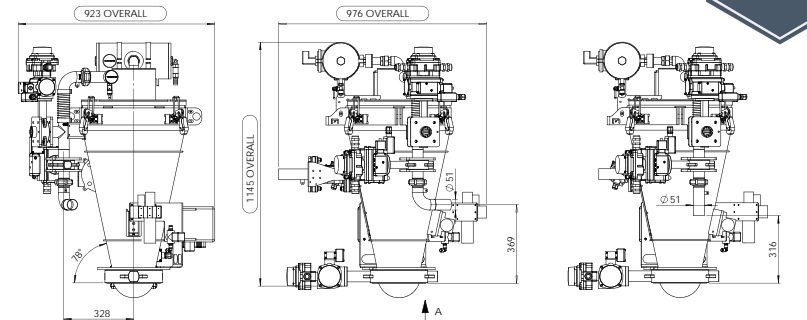
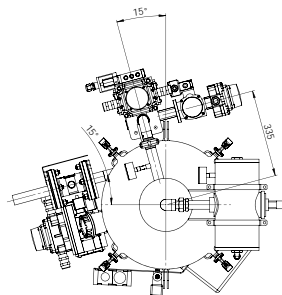
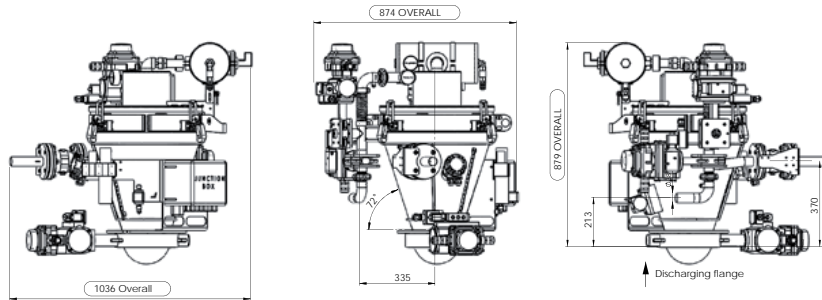

VFlow® 03



VFlow® 04



VFlow®

03

Dense phase vacuum conveying: powder pump

- Model:** VFlow® 03
- Rate:** 2.5 to 4 m³/h.
- Overall height:** 1.357 mm.
- Volume of the cyclone:** 40 liters
- Manufacturing quality:** Ra < 1.2 to 0.8
- Cyclone body manufacturing:** 304(L) stainless steel, 316(L) stainless steel
- Size of the particules transferred:** from mm. to µm
- Operating temperature:** -10°/+ 40°
- Vacuum pump technology:** without lubrication, with dry paddles or nozzles
- Tare weight:** 145 kg
- Maximum vacuum transfer:** 800 Nm³/h.
- Air consumption*:** 0.80 to 1.23 m³/h.
- *Flow rate at atmospheric pressure, maximum and minimum rates
- Operating pressure:** 6 bars
- Filter manufacturing:** polyester, PTFE coated, stainless steel deployed inside
- Filtering area:** 2.8 m²
- Unclogging tank volume:** 6.5 liters
- Level probe characteristics:** capacitive (on request according to product)
- Unloading valve technology:** butterfly Ø DN250
- Valve body:** cast iron or 316L stainless steel
- Valve disc:** 304(L) stainless steel, 316(L) stainless steel
- Product valve technology:** pinch
- Vacuum valve technology:** butterfly with pneumatic actuator
- Air suction pipe Ø (mm):** DN65
- Product suction pipe Ø (mm):** 63 - 76
- Piping type:** rigid and flexible (reinforced piping with electrical spiral for metallic continuity)
- Connections:** SMS, clamp, flange
- Power required:** 5.5 to 11 kW
- Inlet:** 2
- Outlet:** 5
- ATEX compatibility:** 20, 21, 22 and 1, 2
- Pump flow rate m³/h.:** 350

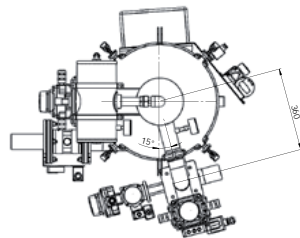
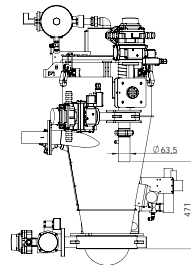
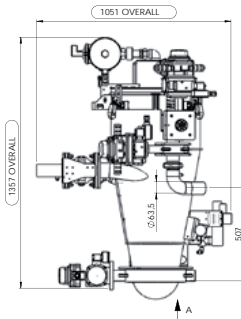
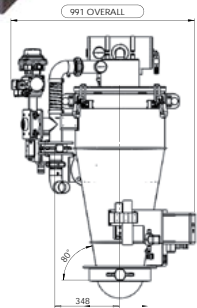

04

Dense phase vacuum conveying: powder pump

- Model:** VFlow® 04
- Rate:** 4 to 6 m³/h.
- Overall height:** 1.420 mm.
- Volume of the cyclone:** 55 liters
- Manufacturing quality:** Ra < 1.2 to 0.8
- Cyclone body manufacturing:** 304(L) stainless steel, 316(L) stainless steel
- Size of the particules transferred:** from mm. to µm
- Operating temperature:** -10°/+ 40°
- Vacuum pump technology:** without lubrication, with dry paddles or nozzles
- Tare weight:** 170 kg
- Maximum vacuum transfer:** 800 Nm³/h.
- Air consumption*:** 0.63 to 0.92 m³/h.
- *Flow rate at atmospheric pressure, maximum and minimum rates
- Operating pressure:** 6 bars
- Filter manufacturing:** polyester, PTFE coated, stainless steel deployed inside
- Filtering area:** 7.8 m²
- Unclogging tank volume:** 6.5 liters
- Level probe characteristics:** capacitive (on request according to product)
- Unloading valve technology:** butterfly Ø DN250
- Valve body:** cast iron or 316L stainless steel
- Valve disc:** 304(L) stainless steel, 316(L) stainless steel
- Product valve technology:** pinch
- Vacuum valve technology:** butterfly with pneumatic actuator
- Air suction pipe Ø (mm):** DN80
- Product suction pipe Ø (mm):** 76 - 88.9
- Piping type:** rigid and flexible (reinforced piping with electrical spiral for metallic continuity)
- Connections:** SMS, clamp, flange
- Power required:** 11 to 15 kW
- Inlet:** 2
- Outlet:** 5
- ATEX compatibility:** 20, 21, 22 and 1, 2
- Pump flow rate m³/h.:** 400

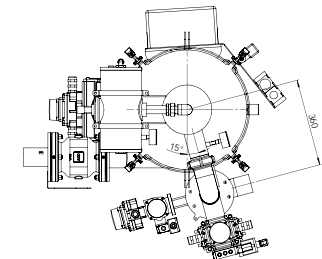
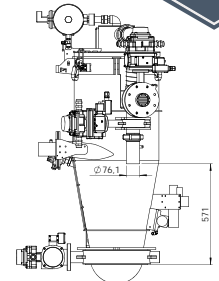
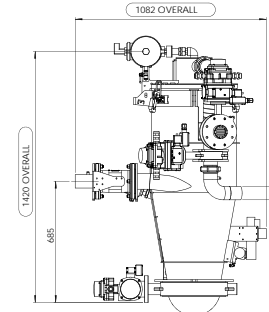
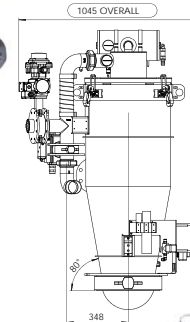

05

Dense phase vacuum conveying:
powder pump



Model: VFlow® 05
Rate: 5 to 10 m³/h.
Overall height: 1.883 mm.
Volume of the cyclone: 70 liters
Manufacturing quality: Ra < 1.2 to 0.8
Cyclone body manufacturing: 304(L) stainless steel, 316(L) stainless steel
Size of the particules transferred: from mm to 3 µm
Operating temperature: -10°/+ 40°
Vacuum pump technology: without lubrication, with dry paddles or nozzles
Tare weight: 185 kg
Maximum vacuum transfer: 800 Nm³/h.
Air consumption*: 0.57 à 0.92 m³/h.
*Flow rate at atmospheric pressure, maximum and minimum rates
Operating pressure: 6 bars
Filter manufacturing: polyester, PTFE coated, stainless steel deployed inside
Filtering area: 9.5 m²
Unclogging tank volume: 6.5 liters
Level probe characteristics: capacitive (on request according to product)
Unloading valve technology: butterfly Ø DN300
Valve body: cast iron or 316L stainless steel
Valve disc: 304(L) stainless steel, 316(L) stainless steel
Product valve technology: pinch
Vacuum valve technology: butterfly with pneumatic actuator
Air suction pipe Ø (mm): DN100 - DN200
Product suction pipe Ø (mm): 88.9 - 104
Piping type: rigid and flexible (reinforced piping with electrical spiral for metallic continuity)
Connections: SMS, clamp, flange
Power required: 15 to 30 kW
Inlet: 2
Outlet: 5
ATEX compatibility: 20, 21, 22 and 1, 2
Pump flow rate m³/h.: 500

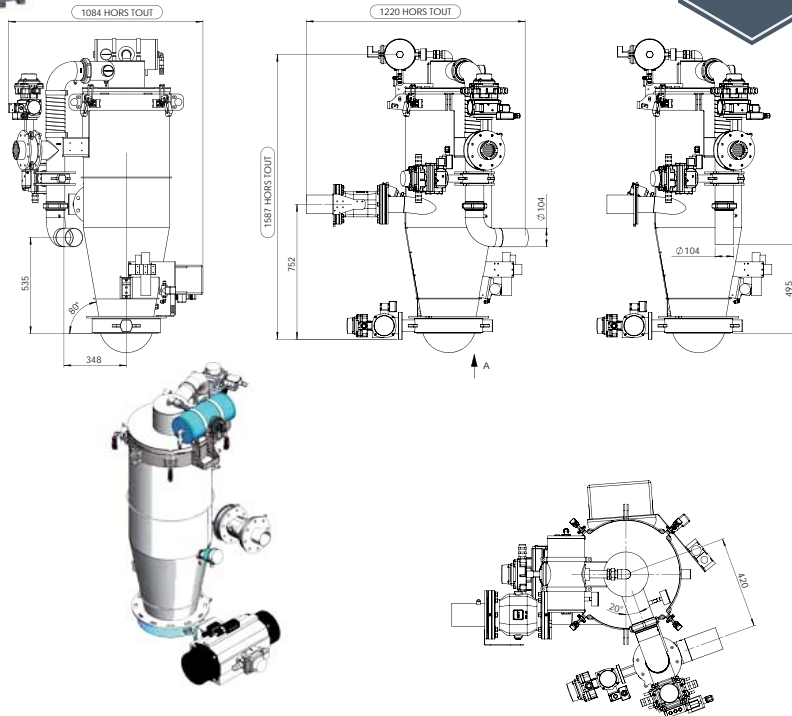

Dense phase vacuum conveying:
powder pump



POSSIBLE FEATURES

- Specific and reduced dimensions
- Applications for toxic materials
- Specific industry as nuclear, petrochemistry
- Manufacturing materials adapted to the conveyed material and the working environment: steel, stainless steel, Hastelloy, Uranus B6, Viton, Perbutan, Nitrile...
- Surface treatments adapted to powders: electropolished, mirror polished, vulcanizing, teflon
- Process functionalities integration: dosing, screening, grinding, granulation, anti-bridging device, mechanical transfer
- ATEX 0-20

See all our options on pages 22-23



Dense phase vacuum conveying

The VFlow® allows a pneumatic **vacuum dense** conveying and prevents the deterioration of the material in a continuously and contained manner in your manufacturing processes.

Particularly adapted to difficult products (poor flow, fragility, abrasiveness or explosiveness of the material), this cyclone can be easily set up in your environment with unlimited extension possibilities.

Suction is performed from multiple feeding points and/or loading several points in your process.

It also allows the feeding of the pressurised reactor and feeding of the material without any addition of air.



C.I.P. FEATURES FOR PNEUMATIC CONVEYING

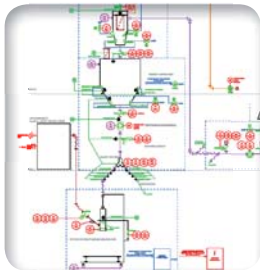

- Set of washing nozzles
- Accelerator pump depending on configuration
- Condensate separator
- Cyclone and tubing cleaned by pickling
- Pipe cleaned by scraping

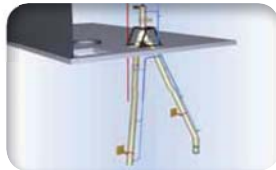

Washing plant



C.I.P. specific design machine



Fillet

WASHING NOZZLES MODELS

STATIC



Pressure: 1.5 to 3 bar
Consumption: 14 to 460 liters/min.

FREE ROTATION



Pressure: 2 to 3 bar
Consumption: 8 to 639 liters/min.

CONTROLLED ROTATION



Pressure: 3 to 5 bar
Consumption: 25 to 193 liters/min.

WASHING CYCLES



Washing head implementation

Cycle example

Type A cleaning process:

1. Rinse solution 80°C with water
2. Water with soda 80°C, soda at 2/3%
3. Rinsing operation with water
4. 1% of nitric acid at 60°C
5. Rinsing operation with water
6. Second and final water rinsing
7. Warm air blowing at 130°C

Type B cleaning process:

The same as the type A but with an air blowing between each step and the use of a WFI water

Cleaning fluid transfer is about 0 to 300 seconds

DETERGENT TYPE

Control of the detergent titrant concentration and recovering of washing waters. Detergent examples:

- Alkaline
- Disinfectant
- Dewatering: solution enabling the acceleration of the installation drying

WASHING WATER RECOVERING

- Water drainage ou shift back to the central through recirculation pump
- Recycling of rinse waters for the pre-washing of the following cycle

DRYING SOLUTIONS

- Natural drying:
- Natural evaporation
- Use of product dewatering
- Warm air sending:
- Warm air station
- Repression of vacuum pump

LOSS-IN-WEIGHT AND DEDICATED LINE

Customer: Dairy, yogurt manufacturing

Treated product: Sugar

Objectives: Feeding of a powder disperser from 2 weighed FIBC unloading units; Flow rate: 5t./h; Integrated purge of the line to ensure dosing accuracy and no cross-contamination



ONLINE SIFTING

Customer: Spices manufacturer

Treated product: Food mixture

Objectives: Online mixture sifting and feeding of a FIBC packing unit; Flow rate: 4t./h.

Advantages: accessibility to equipment for inspection and cleaning



TRANSFER OF COATING GELATIN FOR CAPSULES

Customer: Pharmacist

Treated product: Virgin gelatine

Objectives: Ensure the feeding of the melter with virgin gelatine (separation of fine and grain) and maximum hygiene

Advantages: the pneumatic conveying system provides multiple functions which help to minimize a number of implanted devices



DEMOUNTABILITY OF EQUIPMENT

Customer: Industrial chocolate factory

Treated product: Cocoa, hazelnut powder, vanilla powder

Objectives: Compact design for easy disassembly and cleaning; ATEX Security; Special design for greasy material with poor flowing



VFlow® Detached Filter



Detached Filter

OPERATING MODE

A separating cyclone (offset filter) is coupled with a pneumatic conveying cyclone. The separating cyclone is fitted with a reintroduction nozzle for collecting aspirated fines continuously and for using them again in the process. From a flow rate point of view, the introduction of a separating filter allows to eliminate filter cleaning cycles (10% of a cycle time on average).

TECHNICAL SPECIFICATIONS

Particle sizes: 5 – 3 μm
Average level of vacuum: 500 mbar absolute
Cyclonic efficiency: > 99,5%
Manufacturing materials: 304L stainless steel, 316L stainless steel
Available finishes: outside microblasting, inside electropolishing, inside mirror polishing
Filtering media: PTFE, antistatic PTFE, FDA certified
ATEX certification: zone II 1.2.3 GD (less than 3 mJ EMI).

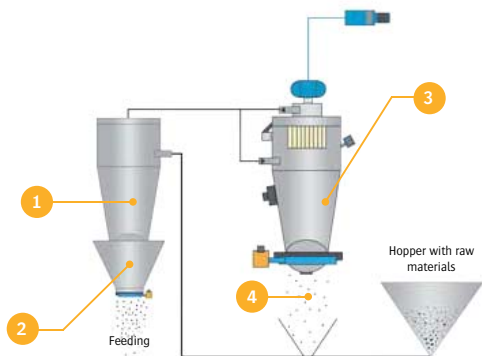

MAIN FUNCTIONS

- Cyclonic:** air/product separation
- Storage:** product recovery, conservation of expansion volume
- Finishes:** separation and protection of the vacuum element
- Reintroduction** into the process line or fines recovery in the dedicated hopper

CYCLOFILTER

SEPARATING CYCLONE

RANGE OF CYCLOFILTERS

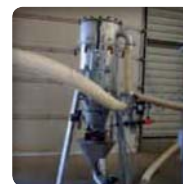
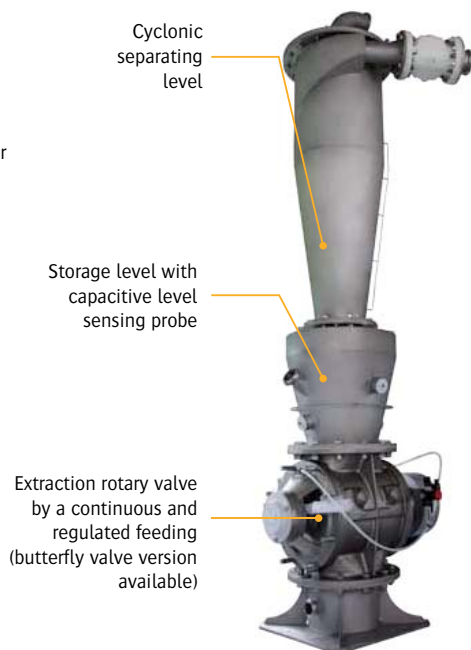
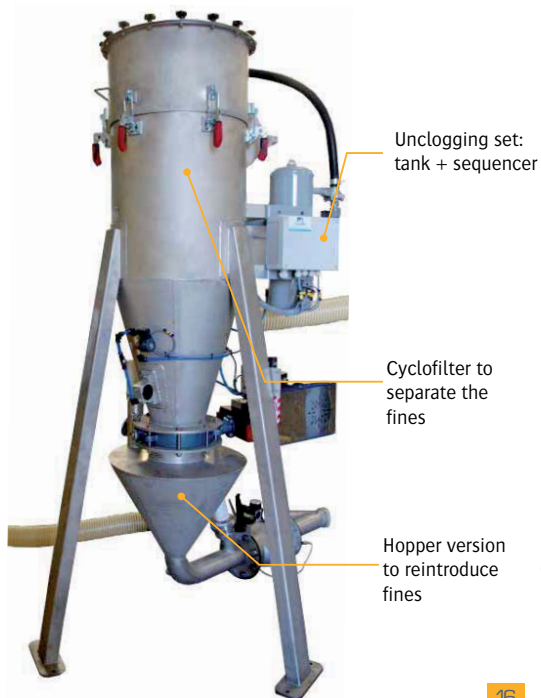

No product loss: reintroduction of the powders into the process



Implementation in harsh environments: loading of reactors in hazardous areas: protection of the filter against emanation of vapors, gas and dust area ATEX certification

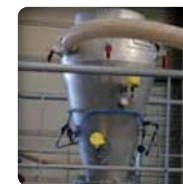

High rate process: optimization of the cyclonic efficiency, reduction of pressure losses, continuous unloading



Difficult product conveying: protection of the filtering system, no clogging in the filter

Advantages

Layout of the VF DEP 06

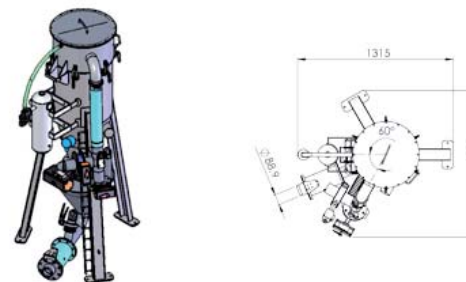
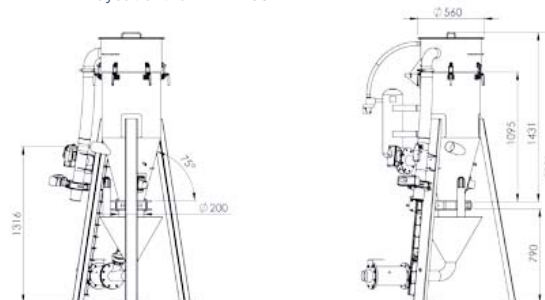

Models	Rate in m ³ /h.	Piping Ø in mm	Filtering surface in m ²	Cyclone outlet Ø in mm.	Cyclone height in mm.
VF DEP 02	2	50	5	100	600
VF DEP 04	4	65	8	150	780
VF DEP 06	6	80	12	150	1.431
VF DEP 08	8	100	18	200	1.850
VF DEP 10	10	125	26	250	2.200

Available options

- ▶ C.I.P.: Clean In Place
- ▶ A SAS for reactor feeding
- ▶ Unloading valve with inflating cuff in harsh environments: emanation of vapors
- ▶ Feeding with Nitrogen

ATEX SECURITY: SPECIFICATIONS AND ADVANTAGES

▶ EXAMPLES OF INSTALLATIONS

▶ MULTIPLE DISCHARGE POINTS

Customer: Catalyst manufacturing for the petrochemical industry

Products: resins, polymers, talc, silica

Objectives:

- Move the operator away from the hazardous area
- Avoid cross contamination
- Ensure weighing

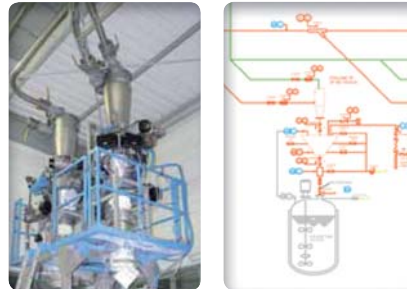

▶ REACTOR FEEDING

Customer: Shampoo manufacturer

Product: wax

Objectives: feeding of 4 high temperature reactors loaded with wax. The dosing is ensured with the loss-in-weight of the FIBC unloading units.

Dosing accuracy: 500 gr.
Flow rate: 4t./h.



▶ DOSING WITH MULTI-POINT DISCHARGE: CONTINUOUS CONVEYING WITHOUT PRODUCT LOSS

Customer: manufacturer of seals for automobiles

Product: carbon black

Objectives: the detached filter allows a floor layout of the filtering cyclone-filter. Maintenance operations are facilitated and centralized on a single device.

Other cyclones are located in height and require no maintenance.



The unique technology of PALAMATIC PROCESS remote filter provides the solution for charging pressurized reactors loaded with solvents.

The entire risk regarding the transfer, draining and recovery cycles of the transfer is completely eliminated by the integration of sensors and additional equipment.

Our many current applications are strong evidence of our expertise in the field of pneumatic conveying.

▶ THE ATEX REGULATIONS: AUDIT AND COMPLIANCE

In their production processes, our customers are very frequently faced with the explosive nature of several materials used (powder, gas, liquid). Huge accidents prove the consequences that an explosion may have. When the atmosphere is explosive, a small spark (e.g. that of an electric switch or from the mechanical heating of a part of the machine) is enough to cause an accident or a disaster. For many years, authorities and industries have worked on developing safety rules governing work conditions in dangerous environments: explosive atmospheres.

PALAMATIC PROCESS offers you its expertise to classify areas in hazardous locations depending on the nature or duration of the presence of the ATEX atmosphere. Today, PALAMATIC PROCESS delivers to its customers ATEX facilities certified by the notified bodies (Inéris, LCIE ...)

PALAMATIC PROCESS has developed standard equipment meeting the ATEX 0-20 / 1-21 / 2-22 regulations.

Also, our specialists engineers conduct zoning and the drafting of risk analyses on new equipment and new facilities.

PALAMATIC PROCESS ensures the safety of operation and full compliance with the standards.



▶ Reactor feeding airlock for barrier and Nitrogen gassing

VFlow® Included Weighing



Included Weighing

This option provides **transfer and dosing** combination. The integrated weigh system allows to control the dosing in masked time and to prepare the batch.



TECHNICAL SPECIFICATIONS

Rate from 1 to 10 m³/h.
Conveying distance: from 1 to 100 m.
Conveying speed: < 5 m/s.
Products: powders, grains, granules...

POSSIBLE TRIALS

Our test station offers you the opportunity to observe, in real conditions, the behavior of your products during the transfer process. This equipment allows technical validation beforehand to secure your investment.

More information on our website:
www.palomaticprocess.com/engineering-design-office/test-plant



The vacuum dense phase conveying technology allows the integration of weighing solutions.

TWO POSSIBLE SOLUTIONS:

1- Loss-in-weight

Loss-in-weight solution consists in weighing the «starting point» of the powder process (sack dumping unit, fibc unloading unit, drum emptying station...). The automaton controls the vacuum through the purge system in order to stop the transfer. To achieve higher accuracy, a metering element (valve, screw conveyor, rotary valve) can be implemented.

2- Weight gain

The solution for weight gain involves implanting the cyclone on load cells. Once the aspirated quantity coincide with the setpoint, the controller stops the transfer, the dose is ready to be inserted.

LOSS-IN-WEIGHT

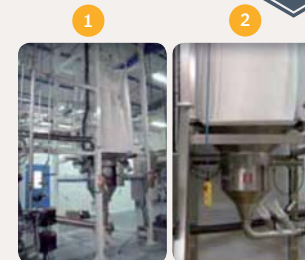
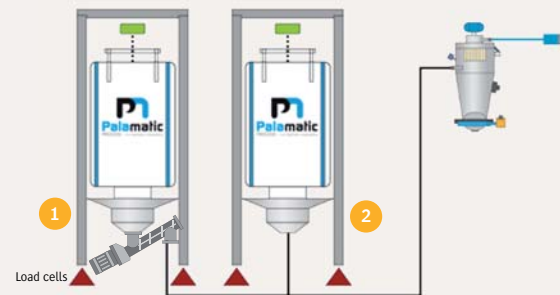

1 A controlled feeding thanks to a screw conveying or a rotary valve. Using of frequency converter to get a very precise dosing < 1 kg

2 Direct feeding: the dosing is stopped by a weighing valve, accuracy < 5 kg

The loss-in-weight of the starting points combined with line purging provides complete dosing for conducting the premix.

WEIGHT GAIN

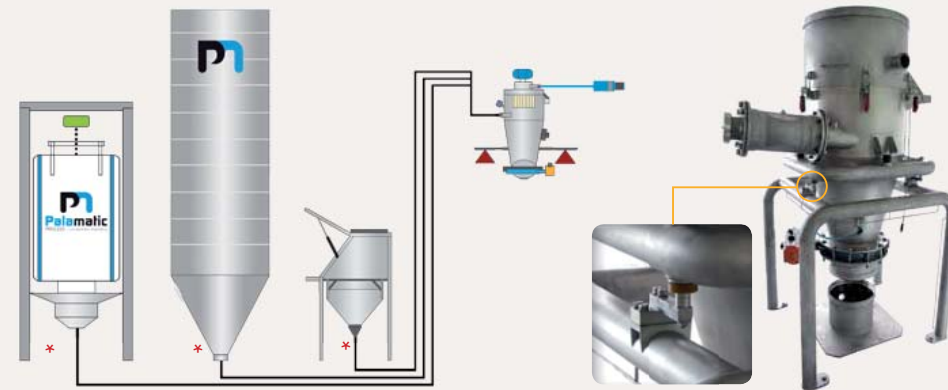

*Direct feeding or by a metering unit depending on the accuracy desired

The conveying system ensures the «pumping» of the product to reach the target weight. During unloading, return to «zero» ensures total introduction of material into downstream equipment.



➤ Precision < 1 kg and < 50/100 gr. with a metered feeding



➤ Line venting



➤ Dedicated line: no cross contamination



➤ Display

Advantages



▶ EXAMPLES OF INSTALLATIONS



Cyclone transfer system with dosing device

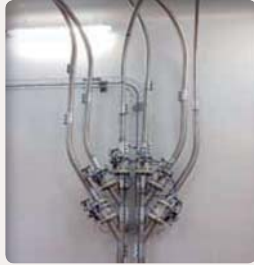

Multi-line for the feeding of the weighed cyclone; allows the production of the pre-mix during the transfer phase



Vacuum pneumatic conveying with integrated «weight gain» scale. This pattern is specially designed for the suction of multi-components



Customer: plant for preparation of ready-to-cook dishes

Products: wheat flour, rice flour

Objectives: suck a specific batch of flour with respect of the doses of the pre-mix in masked time.

Characteristics: the buffer capacity of the cyclone permits the storage of 800 kg for a «snapshot» feeding of the mixer located downstream.



Customer: food cooking breaded meat

Products: starch, carbonates

Objectives: pre-mix production in masked time with respect of the recipes.

The weighed cyclone operates in technical roof spaces to create production space in clean area.

Flow rates: 4t./h.



Customer: yogurt manufacturing plant

Products: sugar and proteins

Objectives: buffer storage of raw materials in hoppers. The VFlow® 04 pneumatic conveying directly sucks the raw materials. The loss-in-weight device controls suction to ensure the conveying of the desired doses.



▶ SUCTION PIPE

Effortless suction of the product

Hand operated device to allow the suction of the product. The suction pipe is the ideal solution for drums, sacks, octabins or buckets unloading.



▶ ATEX 20, 21 ET 22

The ATEX zoning conditions the design of the pneumatic transfer system.

Depending on your ATEX zoning, the pneumatic transfer system is composed of ATEX equipment, nitrogen unclotting, CODAP manufacturing...

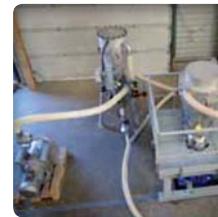

▶ DETACHED FILTER

It provides air/material separation at 99.5% in the separating cyclone located directly on the tanks and reactors (compatibility with the environment not favorable).

The cyclofilter is then deported to the ground with the possibility of re-introduction of fines in the process for products with high added value.



▶ SWITCH

It ensures the flexibility of pneumatic conveying, with multiple arrivals and departure points.

It can be manual or automatic.



▶ ANTI-RISING DAMP SAS

The introduction of the powders comes with a flow of air, compressed air or nitrogen in order to ensure the downward flow of the material and to block the rising of vapors or solvents.



▶ LINE PURGING SYSTEM

It ensures finishing of the transfer cycle with a clean line thanks to a vacuum blast.



▶ CLEAN IN PLACE (CIP)

Suction of the cleaning fluid by means of the transfer system. A liquid separator can be added ahead the vacuum group.



▶ WEIGHT CELLS ON CYCLONE

Weighing of the cyclone provides control of the transfer to monitor the amount of powder sucked or the amount of powder to be drained.



▶ RE-INTRODUCTION OF FINES

When operating remote cyclofilter, the fines from the filtering cyclone are automatically re-introduced into the process by the same transfer system.



▶ AIR GUN

The air jet operated by the air gun has the effect of instantly release a large amount of compressed air which facilitates the flow of product.



▶ VERTICAL CONCEPTION

A specific conception for materials that tend to stick to the walls.



▶ VIBRATING BIN AERATORS

They facilitate the flow and emptying of stored materials. These vibrators allow the introduction of air or nitrogen to facilitate the product flow.



▶ BUFFER HOPPER

Intermediate storage after transfer phase and before material introduction.



▶ PNEUMATIC VIBRATORS

They facilitate the flow and emptying of stored materials. These vibrators generate multidirectional vibrations. They are used for emptying silos or chutes leading.

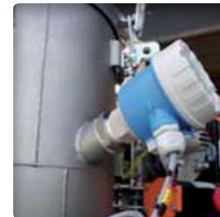

▶ LEVEL PROBE

An extra level sensor may be added to the cyclone to have an additional level.

SERVO-CONTROL, CONTROL, TRACEABILITY

Our automation design office designs and manufactures all of the control cabinet to offer maximum functionality and ergonomics.

The Programmable Logic comes from partnerships with leading market players such as Schneider Electric, Siemens, Omron, Allen Bradley.

The connectivity of our facilities guarantees:

- . Service and evolution continuity
- . Perfect integration into your existing process
- . Flexibility and continuous operation thanks to our remote maintenance service

REMOTE ACCESS - TELEMaintenance

The remote maintenance service allows PALAMATIC PROCESS teams to easily and instantly work on the system without the need to move geographically.

Breakdown assistance provides:

- . Securing the process
- . Reducing stopping time
- . Significant reduction in the cost of interventions
- . Reduced intervention time

This maintenance service of your automation equipment is adaptable over time depending on customer needs.

The implementation of this technical assistance is very simple. All you need is an internet connection, either wired or wireless.

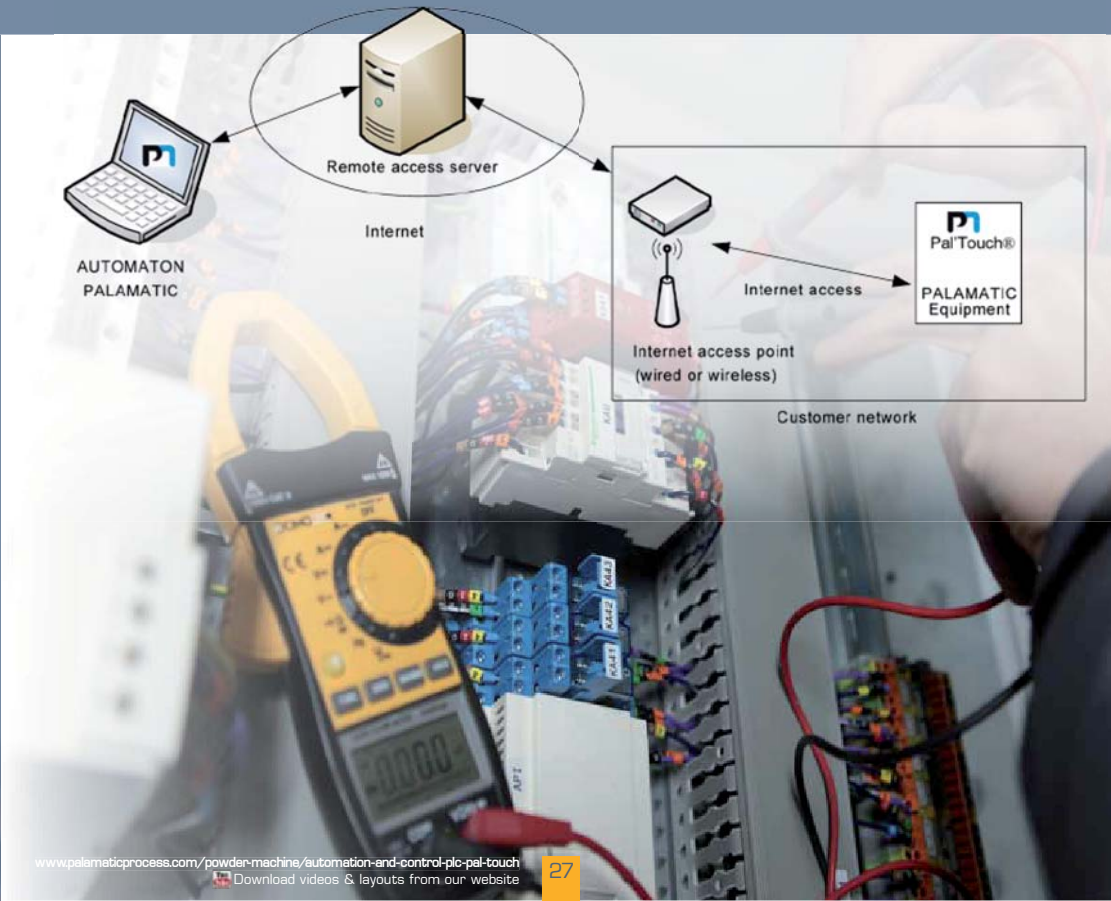



Dense Phase Pressure Pneumatic Conveying

The PALAMATIC PROCESS laboratory for powders was built for the attention of all our industrial customers who wish to set up production machines to meet their expectations.

Our test center is made up of the latest machinery in the powder handling sector. Specialist engineers are there to advise you on the industrial processes best suited to your requirements and to guide you at every stage of the decision to design the most efficient installation.

3 STEPS TO VALIDATE YOUR PROCESS

Step 1 - Before Test

- Select the likely optimal machine configuration based on your technical requirements (powders, flow rate, dosing)
- Draft test proposal by our sales-engineers representatives

Step 2 - During Test

- Process validation for product testing
- Perform testing and sample collection
- Discussion on results after the test with machines (phase diagram, degradation tests, fines content)

Step 3 - After Test

- Analysis of machine test data and samples
- Write a summary report
- Collaborate on the optimal solution for your requirements
- Submit a quotation

THE BENEFITS OF MECHANICAL TESTING

- ▶ Individual consultation and on-going support of our R&D engineers
- ▶ Confirmation of the appropriate machines to conduct a test with your product
- ▶ Tests at various operating conditions to define the most efficient process according to your industrial requirements
- ▶ Evaluation of the profitability of equipment configuration
- ▶ Possibility to test additional options using PALAMATIC PROCESS' range of products
- ▶ Maximize the return of your investment
- ▶ Maximize the optimum selection of the proper machine
- ▶ Capitalize on the wide experience of our experts

- ▶ Come with your materials
- ▶ Participate in selecting the test machines
- ▶ Maximize your productivity

300
+ than **300** configurations

- + than **300** process configurations
- **2,400** sq. feet of surface dedicated to the test
- **35** industrial machines
- **35** feet of ceiling
- Test with **all types of products**
- **2 support engineers**
- **ATEX** configurations



Convey rate: 2 to 100 tons/h.

VERY ABRASIVE MATERIALS CONVEYING

This dense phase pressure conveyor system is suitable for **very abrasive materials**, at all throughput rates and all temperatures.

In this type of pneumatic conveyor, the valve cuts the product flow above the transfer tank. This tank is fitted with a double case and a special output elbow that allows sending the product slowly to the pneumatic conveyor piping. This completely patented dense phase conveying system allows to ensure the elbows for up to two years against abrasion, and to provide a guarantee of 1 000 000 operating valve cycles before general revision. Furthermore, the dispatching valve can be cooled by water circulation, which allows to send materials at very high temperature in the process.

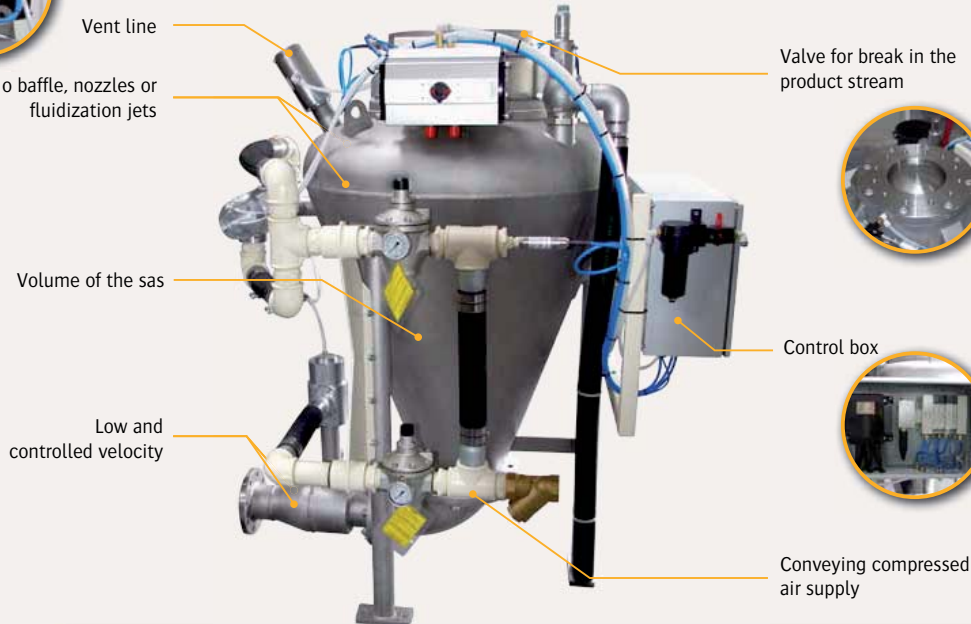

PNEUMATIC CONVEYING RANGE



MINIMAXFLO®
from 15 to 85 liters

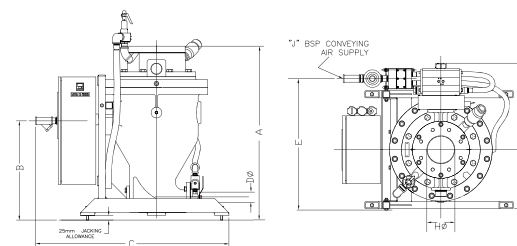

MAXFLO®
from 114 to 3,500 liters

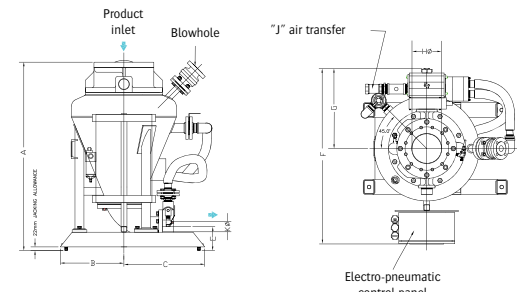

Models	Dimensions in mm.									Weight in Kg
	A	B	C	D	E	F	G	H	J	
15/4-2	718	485	803	25/40/50	725	330	405	100	20	109
30/4-2	923	510	835	40/50	730	335	428	100	20	130
30/6-2	908	510	835	40/50	730	335	428	150	20	142
60/4-2	933	545	1.081	50	734	330	484	150	20	390
60/6-2	968	555	1.081	50	734	330	484	150	20	390
85/8-3	1.114	769	1.290	80	1.028	521	600	200	40	415

Models	Dimensions in mm.									Weight in Kg
	A	B	C	E	F	G	H	J	K	
114/4-4	1.269	400	337	162	1.190	543	200	50	102	335
114/8-4	1.279	400	337	162	1.190	543	200	50	102	455
228/8-5	1.503	400	337	241	1.252	535	200	50	127	525
342/8-6	1.725	400	327	252	1.285	533	200	63	152	555
342/12-6	1.807	400	327	235	1.131	521	300	63	152	753
570/12-8	2.026	400	400	219	1.127	435	300	76	203	1.157
857/12-10	2.276	480	502	305	1.153	375	300	76	254	1.501
1428/12-12	2.956	480	502	337	1.607	781	300	76	305	2.019
2125/16-12	3.680	480	495	305	1.607	781	400	101	254	2.450
2825/16-12	4.230	480	502	337	1.848	898	400	127	305	3.130
3500/16-12	4.759	480	502	337	2.247	1.092	400	153	305	3.850

Advantages



▶ Limited abrasion and segregation



▶ Long conveying distances

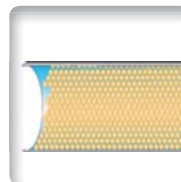

▶ Very high convey rates



▶ Optimized design to meet specific needs

▶ PNEUMATIC CONVEYING RANGE - DENSE PHASE PRESSURE



▶ OPERATING MODE

1. Airlock filling by the dome opening and the vent line (pinch valve)
2. End of filling controlled by temporization. Valve closure in the material column. The airlock is 100% filled
3. The airlock is sealed by the vent line closure and the pressurization of the dome seat
4. Pressure rising of the airlock and starting time for the material evacuation
5. Degassing of the airlock by vent line and cycle reset

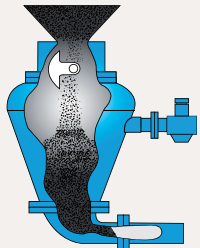

Introduction of the material in the sas

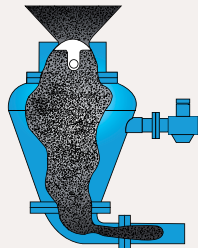

Closure of the valve in the product = reduced air consumption
The airlock is filled at 100%

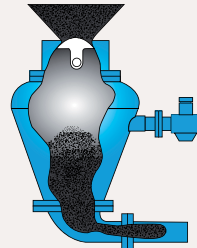

Controlled introduction of air

▶ TECHNICAL SPECIFICATIONS

Particle size: from very fine (ash) to big (peanuts)
Overpressure average level: 4 bars
Manufacturing: cast iron, 304L and 316L stainless steel
Compressed air consumption: 2 to 114 Nm³/min.
Maximum conveying distance: 700 m.
ATEX Certification: zone II 1,2,3 GD (EMI less to 3 mJ)
Maximum temperature: 280°C
Maximum operating temperature: > 300°C
Inlet Ø: 50 to 600 mm.

▶ ADVANTAGES

- . For granules, powders and mixtures
- . Slow and smooth conveying, with less compressed air and energy consumption
- . A simple system and not contaminating
- . Less wear due to low conveying rate
- . Without mixtures damages
- . Stainless steel construction for sanitation or corrosion resistance

▶ CASE STUDY

Realization of an assembly of pneumatic conveying to feed sack filling machines:

- 2 feeding silos
- 4 packaging lines

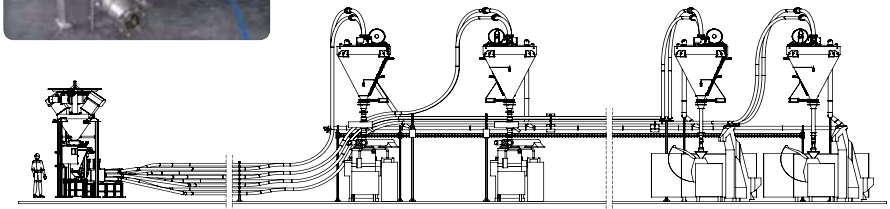
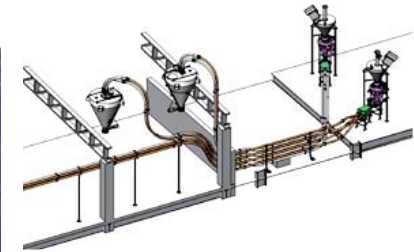

▶ EXAMPLES OF INSTALLATIONS



Loading tank cars



Long convey distances



Dedicated high-rate line

Pneumatic Conveying

Why our pneumatic systems are the most air efficient in the market ?



The Inflatek® valve is unique in its ability to close and to ensure sealing in a single action, through a column of static or mobile material. This feature ensures complete filling of the tank. Air consumption is strongly minimized.

Sealing is provided by the inflation of elastomeric sealing gasket which prevents wear from erosion of the seat and of the seal of the valve.

The Inflatek® valve has a nominal capacity of one million cycles between each inspection, which almost eliminates the maintenance operation and costly production downtime.

ADVANTAGES

The Inflatek® valve was specially developed for pneumatic transfer tanks.

- No abrasion
- Tight and sealed closing thanks to an inflatable seal
- Tight and sealed closing thanks to a static or moving product column
- Pressure: 43 bar
- Temperature: 280°C
- Size: 50 - 600 mm

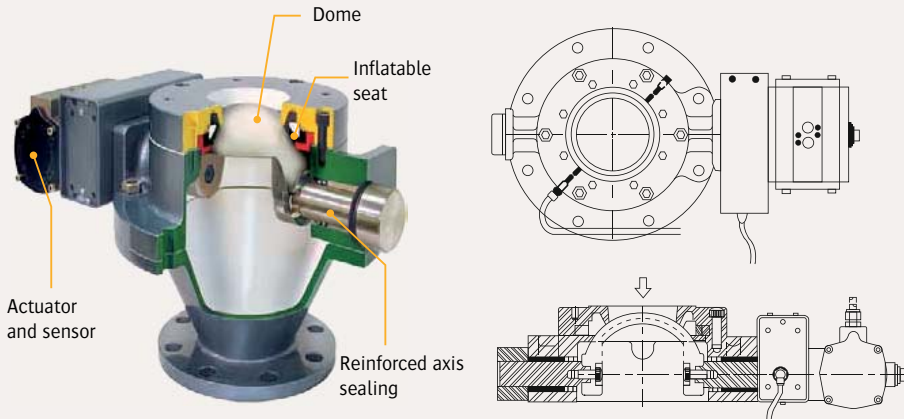

TECHNICAL FEATURES

▶ **Abrasive materials:** abrasive slurries, powders, bulk granules and gases loaded with dust cause erosion of the seat and the inefficient closure of classic valves. The inflatable seal and its function of automatic compensation overcomes the problems related to wear because of abrasive materials.

▶ **Differential pressure:** this pressure usually causes the rapid wear of the seat due to non-caught particles and transportation at high speed. The inflatable seal allows to effectively catch particles to prevent their movement and thus the premature wear of the machines.

▶ **Closing and sealing:** the movement of the dome enables complete closure in the bulk material column and the action of the inflatable seal allows a perfect sealing.

Additional information

The inflatable seal is available in different polymer versions according to the material ranges from abrasive dusts to food products.

If the material flows into the vacuum or remains static within a column, the valve is designed to stop the transfer and provide a complete sealing.

Examples of Installations

U.S. DEPARTMENT OF ENERGY

Objectives :

- Minimum particle size degradation
- Low operation cost

Retrofit of a poorly designed pneumatic conveying system for run-of-mine coal fuel size 50 mm. Low velocity, dense phase coal handling for rotary grate coal fired boilers and dust-free yard storage. The coal transfer system has been developed to maintain a low velocity of the coal fuel. In addition to minimizing material degradation, the low velocity ensures very little or no pipe wear.

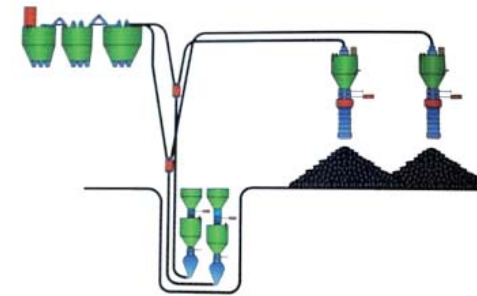

Basic data:

- Coal fuel
- 2 X low velocity conveying systems (50 mm)
- 5 reception point
- Ambient temperature
- 40 t./h.

ALLEN SUGAR

Objectives:

- Minimum particle size degradation
- Low operating cost

Allen Sugar required the most modern handling system for fragile granular sugar and dextrose without any change to the product grain size or shape. Exacting degradation limits were established for pre-contact engineering.

The system satisfied all objectives with negligible degradation of the sugar granule or the dextrose material.

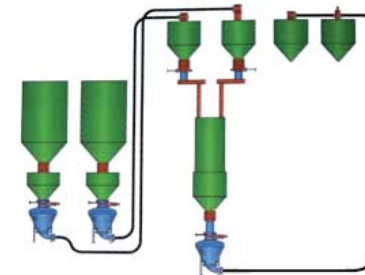

Basic data:

- Sugar, dextrose
- 3 low velocity conveying systems
- 2 to 5 reception points
- Ambient temperature
- 12-30 t./h.

Examples of Installations



Dilute Phase Pressure Pneumatic Conveying Blower

BRUNNER MOND

Objectives:

- Minimum particle size degradation
- Operating reliability

Customer manufactures sodium bicarbonate which is used for a wide range of individual and consumer products. The quality of the product depends upon the consistency of the particle size distribution with a severe limit on fines content. To satisfy these requirements, low material velocity is required, which was achieved by the pneumatic conveying system.

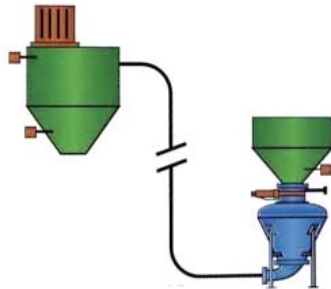

Basic data:

- Sodium bicarbonate
- 1 low velocity conveying system
- 1 reception point
- Ambient temperature
- 22 t./h.

ACE HARDWARE

Objectives:

- Operating reliability
- Accurate weighing
- Low operating cost

A loss-in-weight batch weighing control is provided at each transfer unit. Any of six different materials is introduced to the system for pre-weight and transfer to any of six receiving bins. TiO₂ is an unusual material which exhibits cohesive characteristics from its grain shape even when dry and apparently free flowing.

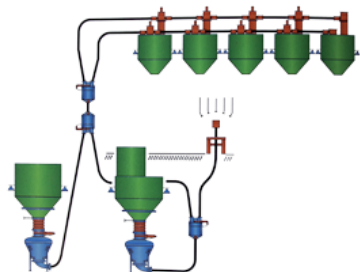

Basic data:

- Titanium dioxide (TiO₂) and other materials
- 2 X low velocity conveying systems (150 mm)
- 6 reception points
- Ambient temperature
- 25 t./h.



Pneumatic Conveying

Convey rate: from 100 kg to 60 t.

OVERPRESSURE PNEUMATIC CONVEYING

This pressure dilute phase pneumatic conveying allows to **transport bulk products, powders and granules with high flow rates** over long distances.



Dilute Phase Pressure



TECHNICAL SPECIFICATIONS

Dilute phase pressure conveying systems use positive displacement (root type) blowers providing air to convey materials through a pipeline to the destination where the air and product are separated by a filter or other system. The product must enter the convey line, which is at higher pressure, via a special feeding device, usually a rotary valve airtight or a venturi. The product is frequently suspended in the air flow, moving at relatively high velocities depending on the particles sizes and densities. Systems generally operate on a continuous basis; product is constantly supplied at the starting point and arrives at the destination without interruption. It allows this type of system to be easily adapted for dosing and continuous weighing applications.

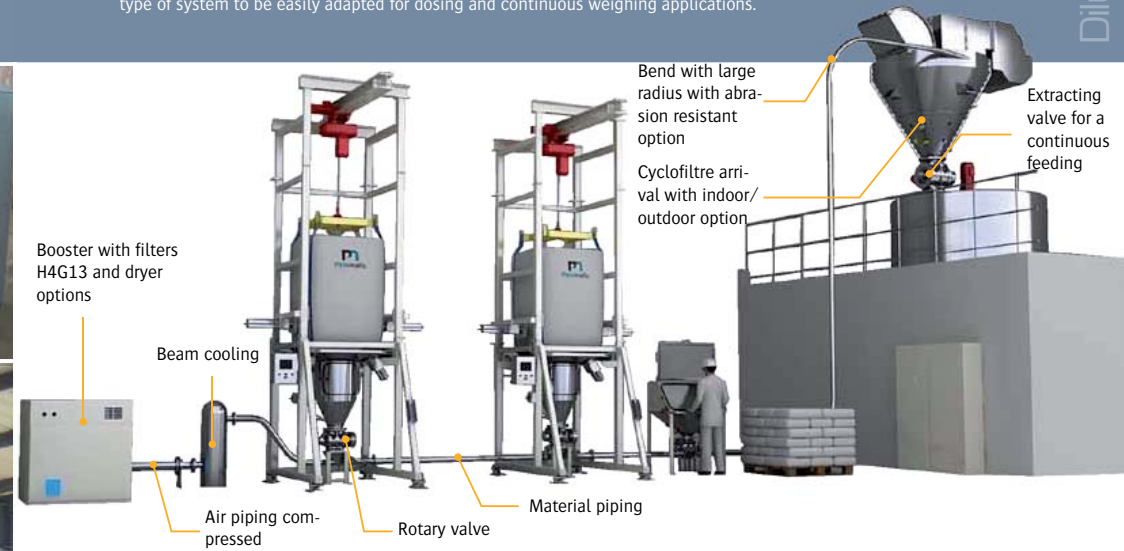

2 BLOWING TECHNOLOGIES

1- SIDE CHANNEL BLOWERS

Side channel blowers, through their internal compression on several levels, generate low pulsation blown air. Lateral canal blowers generate through their internal compression on several levels air-blown low pulsation. The basic construction of the paddle wheels and the arched shape of its pallets guarantee a better performance. Economical, robust and compact, the blowers with side channel are adapted to continuous operation of pressure pneumatic conveying.

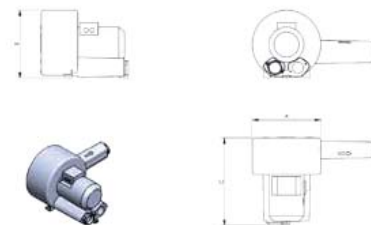
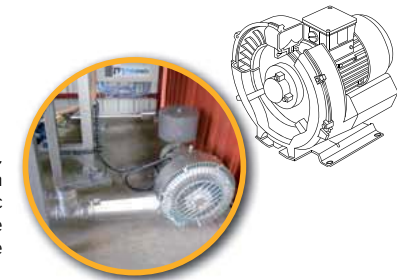

Models	Flow rate in m ³ /h.	Pressure in mbar	Dimensions in mm.			Power in Kw	Weight in Kg
			A	B	C		
BLO-14	140	400	285	337	650	2.2	20
BLO-21	215	475	327	380	755	4	34
BLO-41	416	475	424	487	965	7.5	71
BLO-65	657	575	492	601	995	15	90
BLO-80	804	600	516	613	1.105	18.5	106
BLO-100	1.007	475	548	628	1.183	22	112

3 TECHNOLOGIES TO RECEIVE THE POWDERS

2 - «ROOTS» TYPE BOOSTER

This rotary piston blower is particularly suitable for compression and air suction. Used in pressure dilute phase pneumatic transfer, its large flow range, important capabilities of overpressure and ease of maintenance make it a reliable and comprehensive industrial equipment. The booster is integrated into a totally enclosed unit that is equipped with a cooling fan, a soundproofing device, a transmission via pulleys/belt, a silencer and a non-return valve, a pressure switch and a thermostat for a rapid installation of the assembly.

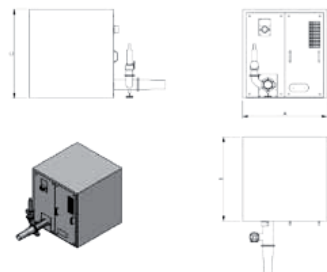

Models	Flow rate in m ³ /h.	Pressure in mbar	Dimensions in mm.			Power in Kw	Weight in kg
			A	B	C		
LOB-10	220	950	770	720	850	7.5	220
LOB-30	450	1,050	1,200	1,000	1,210	11	440
LOB-65	600	620	1,200	1,000	1,210	15	480
LOB-125	1,480	1,050	1,240	1,400	1,390	45	1,035
LOB-230	2,500	1,000	1,560	1,660	1,410	90	1,640
LOB-600	6,000	1,100	2,660	1,810	2,640	132	2,700

3 TECHNOLOGIES TO INSERT THE POWDERS

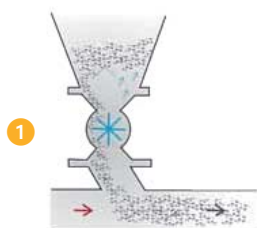

Rotary valve with speed-up box for material conveying

Advantages

- Limits pressure rising
- Reduces abrasion
- Loading capacity: from 2.5 to 58 liters/rev.



The material is directly blown into the **blow-through rotary valve**

Advantages

- Economical solution
- Space saving
- Loading capacity: from 2.5 to 58 liters/rev.

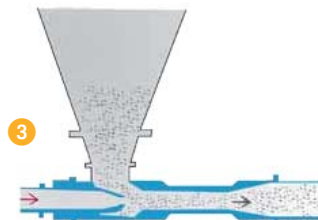

Venturi / Eductor
Direct handling of the product create depression below the hopper

Advantages

- No rotating equipment
- Ideal for light products on short to medium conveying lines
- DN 50 to 150 mm.



1 CYCLOFILTER

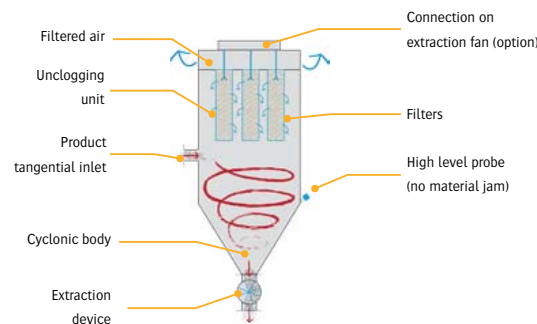

It ensures the separation of the conveying air and the material. The extraction of the material is provided by the rotary valve. Filters are unclogged by automatic sequencers.



2 EXPANSION CHAMBER

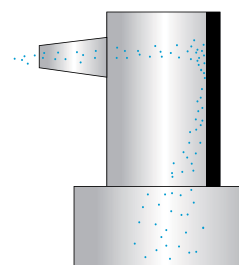

- Set on the hopper, it ensures the stopping of the product thanks to a shield.
- The hoppers are thus protected from abrasion.
- The filling is done with a «shower» of product.
- Removable and replaceable hitting plate.



3 SILO

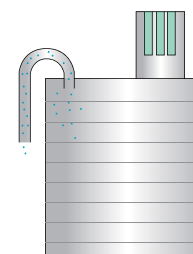

- The silo ensures the decompression of the conveying air.
- The integrated filters allow the air / product separation.
- The arrival of the product may be tangential or plunging.



Cyclofilters

TECHNICAL SPECIFICATIONS

Particle size: 1 µm to 3 cm
Overpressure average level: 200 to 600 mbar
Manufacturing: steel, 304L stainless steel, 316L stainless steel
Finishes: RA08, mirror polished, PTFE, antistatic, oleoplastic
ATEX Certification: zone II 1,2,3 GD (EMI below 3 mJ)

RANGE OF CYCLOFILTERS



CYS 01 | CYS 02 | CYS 04 | CYS 15 | CYS 30 | CYS 60



Multi-products conveying



Pipeline cleaner



Feeding of several receipt points



Ease in modifying the circuits

Advantages



DIMENSIONS

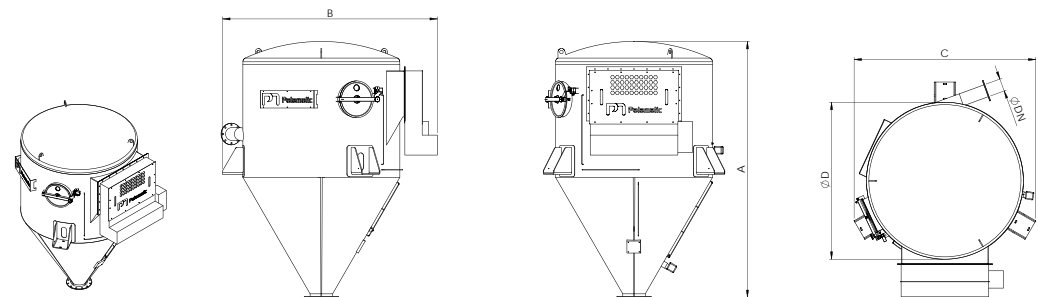

Models	Rate in m ³ /h.	Filtering area in m ²	Dimensions in mm					Weight in kg
			OD	DN	A	B	C	
CYS 01	1	3	800	32	1,980	1,840	840	300
CYS 02	2	3	800	40	1,980	1,840	840	300
CYS 04	4	6	1,200	65	2,350	2,300	1,300	445
CYS 08	8	6	1,200	80	2,390	2,340	1,300	515
CYS 15	15	15	1,800	125	3,030	2,950	2,040	905
CYS 30	30	25	1,800	150	3,600	2,950	2,040	1,320
CYS 60	60	60	2,000	250	5,190	3,400	2,140	2,275

The range of cyclofilters PALAMATIC PROCESS ensures the implementation of all your pneumatic transfer projects.

The quality of filtration allows to transfer all types of materials even the finest or explosive ones.

Manufacturing: stainless steel 304, 316L

Filters: polyester, PTFE, hydrophobic, oleophobic, antistatic...

The design office PALAMATIC PROCESS insures the choice and design of the most suitable cyclofilter according to your applications.

Design Office

Depending on your materials, we size the filtration device and speed transfer to avoid:

- particles segregation
- product breaking
- abrasion



The PALAMATIC PROCESS engineering office puts at your disposal its skills and experience to design powders handling solutions completely custom-made, which will meet your specifications. Our engineers help and support you at every stage of the project through the feasibility study, the 3D designing with SolidWorks, the mounting and tests in our workshop and setting up on your production plant. Because your satisfaction is our priority, you can benefit from our after sales service which is the guarantee of the quality and the reliability of our equipment.



Pneumatic transfer system dimensioning software



Technical questionnaires are available on our Web platform in order to define your project and offer you the best technical solution which will meet your requirements.

Technical questionnaires available on www.palamicprocess.com

TWO WEIGHING SOLUTIONS

Pressure dilute phase conveying allows the integration of two weighing solutions:

- Loss in weight
- Weight gain



1- Loss-in-weight

Loss-in-weight solution consists in weighing the «starting point» of the powder process (sack dumping unit, FIBC unloading unit, drum emptying station...). The controller controls the vacuum via the rotary valve (frequency inverter) to regulate and stop the transfer. In accordance with the length of the conveying line, the PLC controls the end of product. Possible dosing accuracy <1 kg

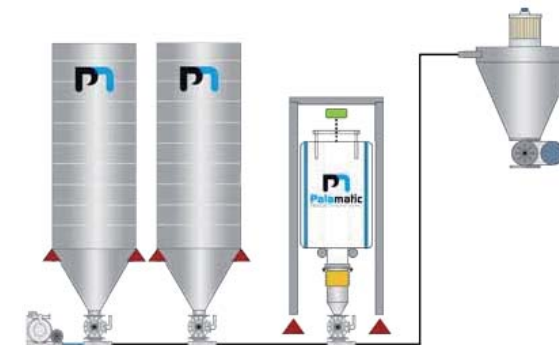

2- Weight gain

The solution for weight gain involves implanting the cyclone on load cells. Once the aspirated quantity corresponds to the setpoint, the controller stops the transfer, the dose is ready to be inserted.

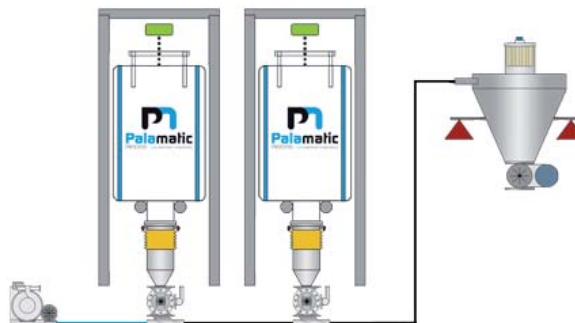

EXAMPLES OF INSTALLATIONS



Examples of Installations

▶ COMPOUND

Customer: manufacturing of plastic granules

Products: talcum, magnesium, mica

Objectives: detached feeding of the extruder from big bags with containment of dust particles (dedusting ring)

Characteristics: rate 5 t./h.

Blowing device: side channel blower



▶ PETROLEUM INDUSTRY

Customer: treatment of drilling muds

Product: cement

Objectives: feeding a silo from an automatic bag emptying system

Characteristics: rate 9 t./h.

Blowing device: blower

Rotary valve with speed-up box

Arrival on silo with expansion chamber



▶ ANIMAL FEED

Customer: phytosanitary products producer

Products: zinc oxide, magnesia, clay

Objectives: multiple arrivals pneumatic transfer from a big bag and sack emptying unit.

Consideration of the abrasive nature of the products

Characteristics: rate 10 t./h.

Blowing device: rotary piston blower



▶ FOOD ADDITIVES

Customer: food mixture manufacturer

Products: salt, sugar, dextrose

Objectives: supply the mixing line with raw material stored in silos

Characteristics: Rate 2,5 t./h.

Blowing device: piston blower

Cyclofilter weighed on arrival



▶ CATALYST MANUFACTURING

Customer: catalyst manufacturing for the petrochemical industry

Product: alumina gel

Objectives: loading of 2 silos of a capacity of 340 m³ with a prior sieving step

Characteristics: rate 15 t./h.

Blowing device: piston blower



▶ FOOD INDUSTRY

Customer: cookies manufacturer

Product: sugar

Objectives: continuous feeding of a PALAMATIC PROCESS mixer for the manufacturing of ice sugar

Characteristics: rate 2,5 t./h.

Fed with a sack dump unit with integrated sifter

Rotary valve with cyclofilter

Atex configuration



Pipes & Switches

Complete range of pipes, bends and switches suitable for all applications.
From Ø 25 to 200 mm for flow rates from a few pounds to several tens of tons per hour.
Special conception for foodstuffs, abrasive materials...

The piping allows the pneumatic conveying of the products. Depending on the type of material selected, it will ensure compliance with product characteristics and the fixed rates. Each application, from the most vulnerable to the more abrasive products, finds its appropriate elbow and switching.

Peripheral Accessories



▶ FLEXIBLE AND RIGID PIPING

- Electrical continuity is ensured by metal spiral
- FDA: food finish
- Reinforced for abrasive products
- Material: polyuréthane
- Transparent to see product passing
- Piping without internal welding (tarif 10)
- Steel and 304, 316 stainless steel manufacturing
- Abrasion resistant coating (PU, steel width)



▶ FITTINGS

- Compression fittings for connecting smooth and rigid pipes between them
- Rapid (Clamp): allow the connection between two rigid tubes. The ends of the tubes must be fitted with smooth flanges.
- With a flange: allow the connection between two rigid tubes but also between any devices fitted with flanges. Fastening is carried out with a screw and a nut.
- SMS: quick connector to screw. To be used with SMS rigid tubes but also between any devices fitted with SMS fitting.
- Clamp and electrical continuity: clamps are used as attachment between the soft and flexible piping.

▶ SWITCHINGS



Manual switch connected by the operator. Control system ensuring quality. Suction and vacuum operation.



Switching with pinch valve for automatic connection to cyclofilters and various starting points.



Automatic by-pass by rotating drum with inflatable gasket ensuring sealing. Suction and vacuum operation. DN80 300



▶ PRESSURE SWITCH

- Electronic sensor providing regulation of the powder dosing in the conveying piping.



▶ PINCH VALVE

- Solution of control and metering for materials such as aggregates, powders, dusts or liquids containing solids.
 - The manufacturing of the body ensures 100% sealing of the fluid.
 - The maximum pressure is between 2 and 6 bar
- Option: recentering ring for pinch protection

DN 25 to 250

▶ BENDS

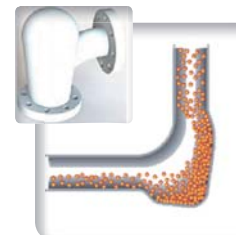

«Cushion of material»
abrasion resistant bend



Abrasion resistant bend
with reinforced extrados

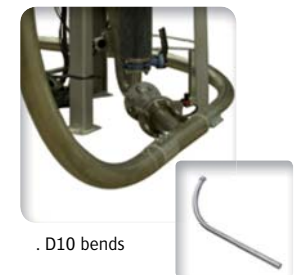

. D10 bends

The piping elements significantly improve the lifetime of conveying transport lines subject to abrasion even in corrosive or high temperatures environments.

Design Guide of ATEX pneumatic conveying system

DESIGN AND CHOICE OF ATEX PNEUMATIC CONVEYING SYSTEM

Depending on the particular characteristics of the processed powders (IME, KST, Particle size...) and site constraints, the pneumatic conveying system can be developed in different ways.

Our technical engineers are at your disposal to design the best pneumatic conveying system. All our machines are adjustable and can be customized according to ATEX zones.

Numerous transmitters (pressure, temperature, oxygenometer) ensure that the conveying system is operational and safe.

There are 3 possible operating principles:

- 1- Dense phase vacuum pneumatic conveying system
- 2- Dense phase pressure pneumatic conveying system
- 3- Dilute phase pressure pneumatic conveying system

1 DENSE PHASE VACUUM PNEUMATIC CONVEYING SYSTEM

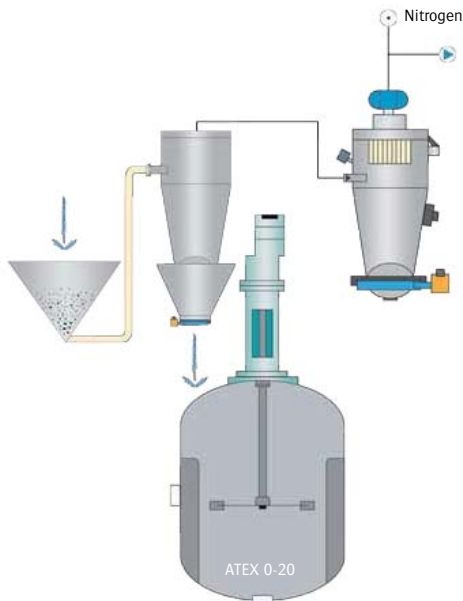

[+] Advantages	[-] Weak points
<ul style="list-style-type: none"> • Security • Implementation cost • Exploitation cost • Low nitrogen consumption (reduced at maximum) • Vacuum operation (depleted atmosphere) • Low filter surface 	<ul style="list-style-type: none"> • Distance < 80 m. • Flow rate < 6 t./h.

The vacuum pneumatic conveying allows a safe and economic environment for all processes with a short or average conveying distance.

Numerous complementary options can reinforce the level of security:

- Control the electric continuity
- Oxygen meter
- Temperature sensor
- Certification SIL2

2 DENSE PHASE PRESSURE PNEUMATIC CONVEYING SYSTEM

This economical solution ensures the protection of equipment for pneumatic conveying of ATEX powders. When dealing with installations in gas area or on reactor, additional options will have to be implemented.

[+] Advantages
<ul style="list-style-type: none"> • Distance • Flow rate • Easy implementation • Multi-points feeding
[-] Weak points
<ul style="list-style-type: none"> • Limited security • Risk of dust emanation outdoor, pressure equipment • Large filter surface

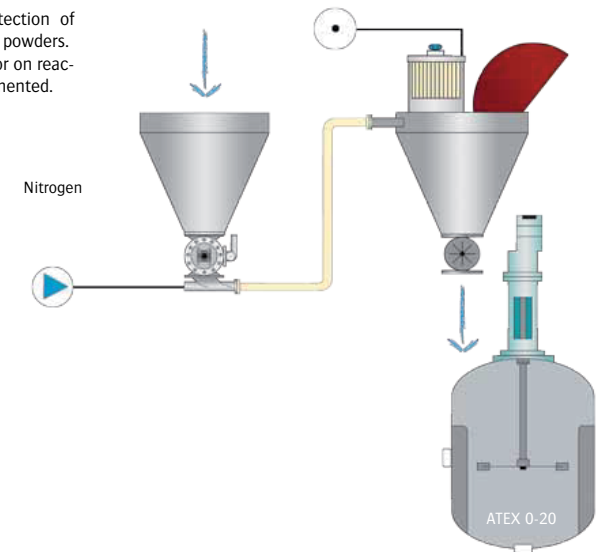

3 DILUTE PHASE PRESSURE PNEUMATIC CONVEYING SYSTEM

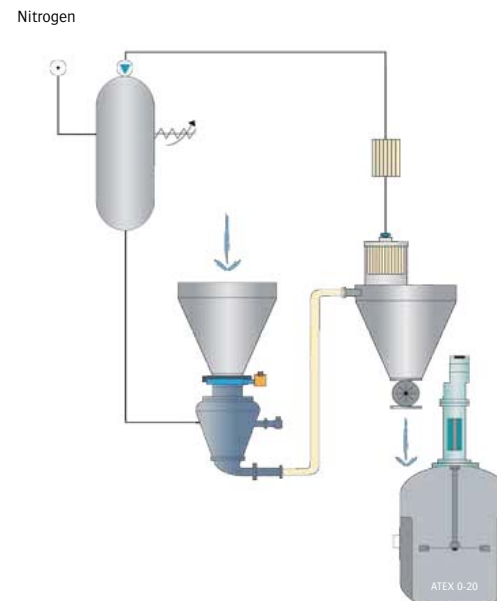

[+] Advantages	[-] Weak points
<ul style="list-style-type: none"> • Security • High flow rate • High conveying distances 	<ul style="list-style-type: none"> • Implementation cost • Complexity of the re-circulation • Exploitation cost

Pneumatic conveying operating in closed loop and under nitrogen pressure recycled at each cycle. This configuration ensures complete inerting of the process line.

Devices used:

- Sas
- Cyclofilter
- Protection filter
- Compressor
- Chiller

ATEX Guide for design of compliant equipment

▶ EQUIPMENT FOR SURFACE INDUSTRIES (GROUP II)

Zone	0	20	1	21	2	22
Type of atmosphere	G gas	D dust	G gas	D dust	G gas	D dust
Explosive atmosphere	Permanent presence		Intermittent presence		Episodic presence	
Category of devices that may be used in accordance with 94/9/CE	1		2		3	

▶ PRODUCT MARKING

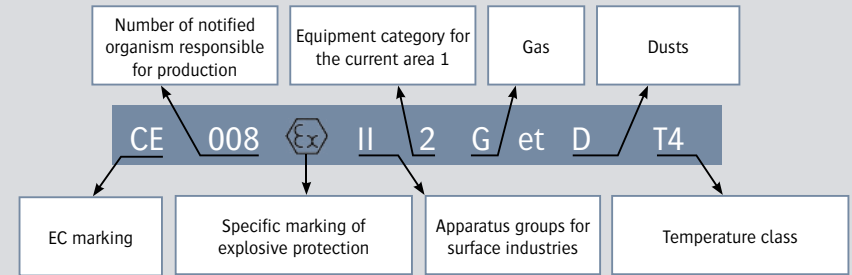

CONFORMITY ASSESSMENT PROCEDURE*

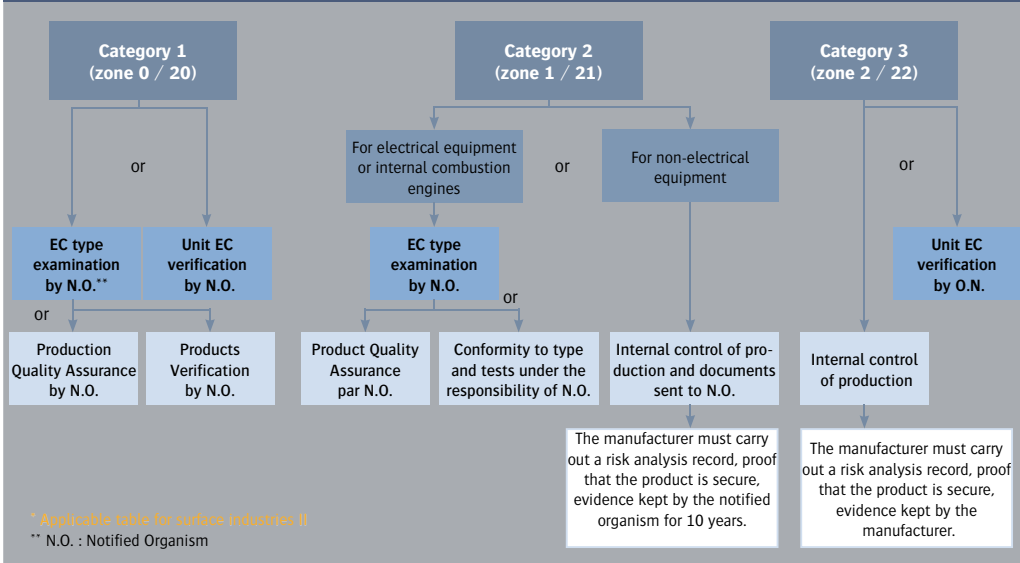

▶ DEGREE OF PROTECTION IP«XX»

Protection against solid bodies		Protection against liquid bodies	
0	No protection	0	No protection
1	Protected against solid bodies ≥50 mm (eg accidental contact of the hand)	1	Protected against vertically falling water drops
2	Protected against solid bodies ≥12 mm (eg fingers of the hand)	2	Protected against water falls inclined at 15 °
3	Protected against solid bodies ≥2,5mm (eg screw tools...)	3	Protected against rain water up to 60 ° from the vertical
4	Protected against solid bodies ≥1 mm (eg fine tools, small cord)	4	Protected against water sprayed from all directions
5	Protected against dust (no harmful sediment)	5	Protected against water jets with lance from all directions
6	Totally protected against dust	6	Protected against water splashes comparable to heavy seas
		7	Protected against the effects of immersion
		8	Protected against the effects of prolonged immersion under specified conditions

▶ GAS GROUPS

Group	Reference gas	MESG (mm)	MIC (mJ)
I	Methane	1,14	0,28
IIA	Propane	0,92	0,25
IIB	Ethylene	0,65	0,07
IIC	Hydrogen/acetylene	0,37	1,011/0,017

MESG: Maximum Experimental Safe Gap
 MIC: Minimum Ignition Current
 For flame arresters, additional subdivisions IIB1, IIB2 et IIB3
 IIB1: MESG > 0,85
 IIB2: MESG > 0,75
 IIB3: MESG > 0,65

▶ DUST GROUPS

Group	Type of dust	Size	Resistivity
IIIA	Suspended combustible particles	> 500 µm	-
IIIB	Non-conductive dusts	≤ 500 µm	>10 ³ Ω.m
IIC	Conductive dusts	< 500 µm	<10 ³ Ω.m

▶ MAXIMUM SURFACE TEMPERATURES

Gas	T1 (450)	T2 (300)	T3 (200)	T4 (135)	T5 (100)	T6 (85)
Dust	450	300	200	135	100	85

Our expertise:

FILLING SOLUTIONS FOR BIG BAG AND OCTABIN

To fill

EMPTYING SOLUTIONS FOR BIG BAG AND OCTABIN

To empty, compact and massage

SACK, DRUM AND CARDBOARD FILLING SOLUTIONS

To fill, package, handle

SACK AND DRUM EMPTYING SOLUTIONS

To empty, compact, handle, discharge

SOLUTIONS FOR PNEUMATIC CONVEYING

Vacuum, pressure

SOLUTIONS FOR MECHANICAL CONVEYING

To transfer with screw, belt conveyor, bucket elevator, aeromechanical or vibratory conveyor, truck loading spout

CRUMBLING AND GRINDING EQUIPMENT

To granulate, crumble, grind, pound, micronise, disagglomerate

SIFTING EQUIPMENT

To sift, segregate, sieve, protect

CONTAINERS AND STORAGE SOLUTIONS

To fill, charge, empty, contain

DOSING EQUIPMENT

To control, regulate, empty, extract

MIXING EQUIPMENT

To homogenise, incorporate, fluidify, stir, mix

FLOW AND CONNECTION

To vibrate, fluidise, unclog, drain, facilitate extraction, control the descent, prevent stacks and vaults, connect

INDUSTRIAL DUST COLLECTING EQUIPMENT

To filter, clean, confine, secure



Palamatic

PROCESS >>> machines • engineering

contact@palamatic.fr

Sales Department: +33 (0)2 22 93 63 08

ZA La Croix Rouge • 35530 Brécé • France

Tel: +33 (0)2 99 86 06 22 • Fax: +33 (0)2 99 86 08 10

SAS au capital de 331 822 euros • R.C.S. Rennes B 384 894 093 • APE 4669B • N° T.V.A. : FR 14 384 894 093